

READY TO RACE

>> www.ktm.com

EN



X-BOW GT

GRAN TURISMO

KTM

GRAN TURISMO

SUPER SPORTS CAR



EXPERIENCE THE MEANING OF SUPER SPORTS CAR COMPLETELY AFRESH

Sports car, noun

/spɔ:ts/ /kɑ:/

a low-built car designed for performance at high speeds

super

/'su:pə

very good, excellent, to an excessive degree

There may very well be super sports cars that live up to this description. Whether it be due to their spectacular appearance. Whether it be due to their outstanding technology. Whether it be due to their breathtaking performance. Or whether it be due to their history steeped in tradition.

However, no other car epitomises the term “super sports car” as thoroughly and uncompromisingly as the KTM X-BOW GT. Based on the KTM X-BOW R – itself unique in the matter of high-tech, safety, drive dynamics and appearance – Austrian manufacturer KTM has created a vehicle whose exceptional characteristics can also be experienced without a helmet. The elegant, frameless windscreen construction, which wraps protectively around the driver and passenger in the same way as a helmet visor, allows the occupants to forego their own headgear. At the same time, however, it does nothing to impair the pure driving experience or the radical design of the revolutionary KTM X-BOW. Quite the contrary!

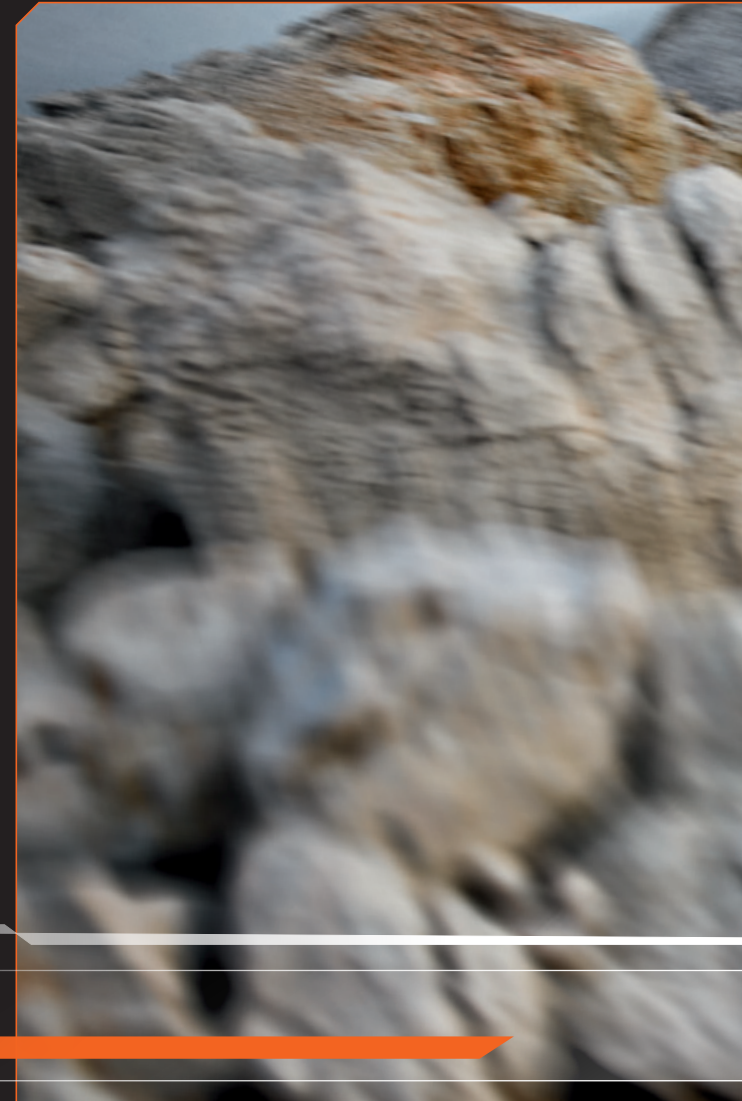





GT

THE EVOLUTION OF A REVOLUTION

The evolution of the KTM design language makes bodywork elements appear more graphic, while just a few sharply drawn lines help to structure the surfaces very clearly.

The engine cover, which has gill-like ventilation slits, connects extensively with the rear bodywork elements that make the rear end – with its stunning shape – appear much more muscular and powerful. The view from the front also surprises with an incredible look: The narrow headlamp surrounds and the bonnets, which are attached over the front splitter at a striking angle, make the whole front end of the KTM X-BOW GT appear even brawnier.

The elements – windscreen and side windows – blend seamlessly into each other, thereby creating the “helmet visor effect”.

The frameless upper edge ensures a flowing transition between “outside” and “inside”: It extends an imaginary line up to the rear bonnets, thereby bestowing the whole vehicle with greater dynamics. The “GT” makes an even wider, lower, more compact and more powerful appearance than ever. The fact that the improved aerodynamics generate less drag and even more downforce goes without saying, due, if nothing else, to the racing genes that are also inherent to this KTM X-BOW. 

0-100 KM/H:
ACCELERATION 4.1 SEC

PROVEN TECHNOLOGY

The technical basis for the KTM X-BOW GT was provided by the "R" model with its 2.0 litre TFSI power unit from engine partner Audi and a carbon monocoque found nowhere else in street-legal production vehicles. So it's hardly surprising that numerous reminiscences of racing are also to be encountered in the interior: The fixed Recaro seat shells, which are integrated directly in the carbon monocoque and ensure excellent safety whenever it's needed, in conjunction with the four-point

safety belts from Schroth, which are just as much part of the standard equipment on the KTM X-BOW GT as the sliding pedal box and the multi-function steering wheel with adjustable height and depth. Experience ergonomics previously unheard of in a super sports car, as the unrivalled field of view has barely changed in spite of the windscreen: The short, slender A-pillars hardly affect visibility at all – the overview is perfect, even when cornering. ➤



GT



REAR END

The large air vents directly over the mid-mounted engine not only ensure perfect ventilation, but also contribute significantly to the look of the rear bodywork elements on the KTM X-BOW GT.



2.8 KG/HP

POWER TO WEIGHT RATIO



THE TRANSFORMATION

The KTM X-BOW GT benefits from the racing genes of the tried-and-tested model and combines them with components and qualities resulting from installation of the windscreen. There are many details to discover in the interior: Behind the shift lever, it's not the ON/OFF button for starting and stopping the Audi engine that sets the tone any more, but the clearly arranged

switches for windscreen wiper, screen wash/wipe system, interior ventilation/heating and the windscreen heater. A technologically sophisticated solution allows integration of particularly thin heating wires in the windscreen, which, in contrast to customary standard solutions, are barely visible even in poor light conditions. ➤➤



CENTRE CONSOLE / COCKPIT

- » Controls harmoniously integrated
- » Tried-and-tested multi-function display and steering wheel



WIND DEFLECTOR

- » Prevents turbulence in the interior
- » Protects from dust

WINDSCREEN

- » Made from laminated safety glass
- » Single-arm windscreen wiper with wash/wipe function
- » Portable sun visors
- » Heatable for quick defrosting

VENTILATION

- » Snorkel for the intake of fresh air
- » Uprated fan
- » Powerful heater

DESIGN

- » Great look thanks to narrower headlamp surrounds
- » Front bonnet slopes down sharply to front splitter
- » Larger front wheel fairings for improved aerodynamics



BELTS

Driver and passenger are protected by a four-point (also six-point upon request) safety belt from Schroth, which is used in racing.



ROLL BARS

In the event of a rollover, optimum protection is guaranteed by the aluminium roll bars integrated in the monocoque. They withstand loads of up to 2.5 times the weight of the vehicle.



CRASH BOX

The crash box at the nose of the vehicle provides additional safety. Thanks to its carbon-aluminium sandwich construction, it even complies with the strict safety regulations of the FIAGT and Formula 3.



MONOCOQUE

The KTM X-BOW is the world's first production vehicle to boast a monocoque made completely from composite carbon fibre material – a trailblazing and pioneering technology, previously reserved exclusively for racing vehicles. Four layers of carbon fibre, epoxy resin, elaborate handiwork, autoclave technology: They all come together

to produce the twin-wall, two-part, extremely lightweight, carbon monocoque, which is manufactured by composite-fibre specialist Wethje in Germany. The result is a carbon-fibre construction that ensures the highest levels of safety, but only weighs 80 kg – with an unbelievably high torsional stiffness of 35.000 Nm/rad.

LIGHT / STIFF / SAFE

COMPOSITE

EFFICIENT HIGH PERFORMANCE THANKS TO AUDI ENGINE TECHNOLOGY

The rear end of the KTM X-BOW GT accommodates a 2.0-litre TFSI engine from premium manufacturer Audi. The state-of-the-art fuel injected power unit combines the dynamics of turbocharging with highly effective charge-air cooling. The engine electronics have been completely revamped for the "GT", with particular attention being paid to drivability. In addition to a maximum power output

of 300 hp, 420 Nm of torque are now available so that the KTM X-BOW GT accelerates from 0 to 100 km/h in only 4.1 seconds. Alongside these outstanding power and torque characteristics, the four-cylinder engine surprises as before with its minimum fuel consumption: only 8.3 liters per 100 km in the MVEG cycle! 

GT

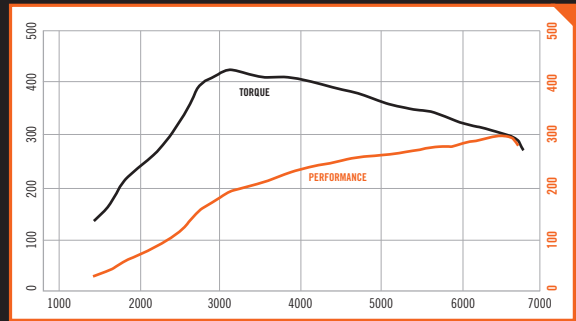

TORQUE CURVE ENGINE MANAGEMENT

The engine achieves its maximum torque of 420 Nm at an engine speed of only 3,200 rpm – thereby making, in the truest sense of the phrase, "very light work" of the KTM X-BOW GT, which tips the scales at a mere 847 kg. The maximum power output of 300 hp is attained at 6,400 rpm.



PERFORMANCE

300 HP / 420 NM



TORQUE SUPPORT

The extreme forces of the engine are cushioned in the KTM X-BOW GT by a torque support, which is mounted directly on the carbon monocoque.



FRAME

The aluminium spaceframe is the central supporting element for the engine/gearbox assembly and is connected to the monocoque by means of horizontal marriage.

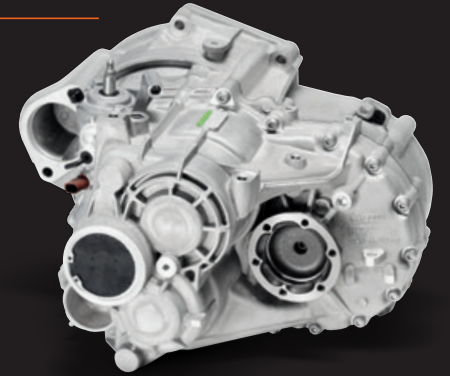

TRANSMISSION

Tried and tested in series production, but tuned optimally to the KTM X-BOW GT. The manual 6-speed gearbox from Audi always has the right gear available.

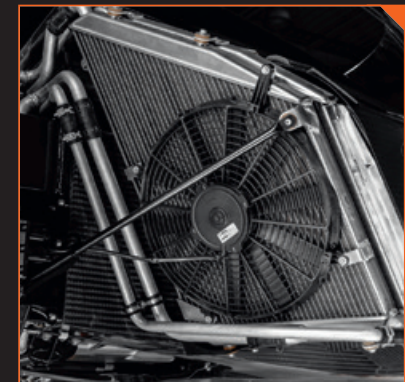

RADIATORS

High-quality products, developed directly by KTM and manufactured in Austria. The high-performance radiators and charge-air cooler originate from WP Radiator.



RACING EXPERTISE FOR THE ROAD

The empirical values for designing the KTM X-BOW were acquired on the racetrack. Motorsport specialist Dallara and KTM Technologies developed the chassis and aerodynamics so uncompromisingly that the KTM X-BOW succeeded in winning

the European GT4 championship in 2008 at the very first attempt. You can experience this victorious technology for yourself in the KTM X-BOW GT. 



CHASSIS

In conjunction with the special tyre mix from exclusive partner Michelin and, as the last link in a very long chain, the springs and dampers from WP Suspension ensure optimum contact with the road surface. On the front axle, the pushrod chassis – derived directly from the world of formula racing – features compression damping with high and low-speed settings as well as adjustable rebound damping. All these setting options are also available on the rear axle, although here the spring/damper unit is directly attached to the wheel mounting.



BRAKES

To counteract its extreme driving power, the KTM X-BOW GT offers the same level of braking power. The Brembo brake system employs a four-piston, fixed-calliper brake on the front axle, with an internally ventilated, slotted disc measuring 305 mm in diameter. The rear unit is a two-piston, fixed-calliper brake with a diameter of 262 mm. The KTM X-BOW GT therefore only needs 32.9 meters to brake from 100 km/h to 0.



TYRES: MICHELIN PILOT SPORT

The innovative “Green Power Compound” ensures excellent grip even on wet surfaces, while also providing low fuel consumption and high mileage. This technology and its extraordinary properties have proven their worth at the very highest level with a total of 12 consecutive victories at the 24-hour race in Le Mans.

AERODYNAMICS

The KTM X-BOW GT supplies technical solutions from the racing world. The design of the ingenious aerodynamics – developed by KTM Technologies in cooperation with Dallara – is particularly impressive. One look underneath the vehicle reveals the three-piece, completely flat, racing underbody derived

from formula racing vehicles. 100 kg of downforce are generated at 200 km/h thanks to the front splitter, underbody and rear diffuser. Depending on the tyres, up to 2.0 g of lateral acceleration are possible – more than with any other street-legal production vehicle. 

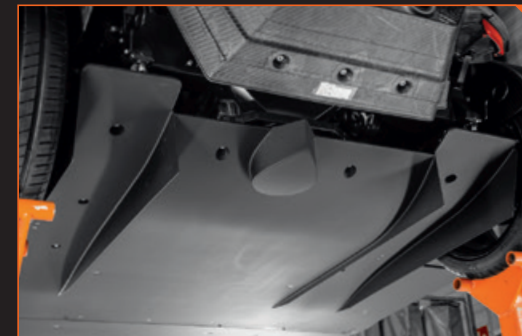

REAR DIFFUSER

Air flows optimally into the rear diffuser, which ensures distribution of pressure on the underbody thanks to its asymmetric design. It generates a large part of the downforce.

UNDERBODY

Smoothly clad throughout and consisting of three parts: The racing underbody of the KTM X-BOW GT.



DOWNFORCE

RACING TECHNOLOGY

POWERPARTS

For all those who like to personalise their KTM X-BOW GT, there is of course a wide selection of PowerParts developed especially for the "GT" model - extending from exclusive paintwork to padded leather seats and even a sat-nav cradle.

SPORTS EXHAUST

This much sound is a must: The sports exhaust system is simple to assemble and coordinates the tone of the vehicle with its spectacular appearance.



LUGGAGE SYSTEM

The ideal solution for all those who want to travel with their KTM X-BOW GT. Thanks to the stylish luggage rack, nothing stands in the way of longer trips accompanied - hopefully - by someone who is just as smitten with speed.

GEAR AND HAND BRAKE LEVER

Lies perfectly in the hand: The CNC-machined, anodised aluminium gear and hand brake levers in an exclusive KTM X-BOW design.

AIR CONDITION

Thanks to this cleverly thought out technology the ambient temperature in the interior of the KTM X-BOW GT is reduced for about 15° Celsius, even in the most extreme summer heat. Adjustable vents on both driver and passenger's sides distribute the cooled air while the unit is simply operated via a dedicated switch on the center console.



X-TOP

Dispense with anything that distracts from the driving experience: the KTM X-BOW fulfilled this requirement superbly - and the "GT" does so, too. The "X-TOP" - a soft cover that can be stored inside the vehicle - is sure to keep the KTM X-BOW GT's interior dry.

PADDED TEXTILE / LEATHER SEAT COVERS

The seat shells from KTM's exclusive partner Recaro form the basis for the more comfortable, visually stunning alternative: textile/leather seat covers with colour-contrasted seams.

MULTIMEDIA INTERFACE

The KTM X-BOW multimedia interface offers a variety of technical gadgets and comfort elements. The basic features are: reverse cam, music player, USB port and hands-free calling. Thanks to the possibility of internet access and the App-Market there are no limits for individualization. The whole system is controlled by a 5" Multi-Touch Screen.

BBS WHEELS

Wider, lower, more compact, more powerful. The look of the KTM X-BOW GT is rounded off by the 18 and 19-inch wheels from BBS with replaceable rim rings.

ALL POWERPARTS CAN BE FOUND AT:
www.ktm.com/xbow





THE COLOURS FOR THE KTM X-BOW GT

An exceptional, extrovert vehicle such as the KTM X-BOW GT calls for spectacular colours. Alongside the simple, but perfectly coordinated colour scheme of "Electric Orange" and "Pure White", there are therefore another five stunning colours

available as PowerPart: "Original Blue", "Fusion Orange", "Combat Grey" and "Python Green", as well as the time-honoured "Carbon Black".



PYTHON GREEN



ORIGINAL BLUE



COMBAT GREY



ELECTRIC ORANGE



PURE WHITE



FUSION ORANGE



CARBON BLACK

COLOURS / STANDARD



ELECTRIC ORANGE



PURE WHITE

POWERPARTS PAINT COLOURS



PYTHON GREEN



ORIGINAL BLUE

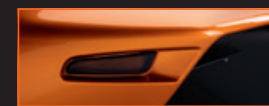

FUSION ORANGE

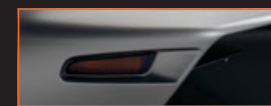

COMBAT GREY



CARBON BLACK

COLOURS GRAN TURISMO

PRODUCED PERFECTLY BY HAND

The KTM X-BOW has been manufactured in a special-purpose plant in Graz since June 2008. One of the world's most modern vehicle limited-production facilities was built in a matter of months here in accordance with the latest standards. At the same time, KTM developed ingenious warehousing, special transport logistics (including specially designed transport containers for the valuable carbon-fibre parts) and special assembly technologies. Around 100 examples of the KTM X-BOW in its "R", "RR", "GT4" and "GT" versions are produced with the greatest precision every year by a small team of specialists. However, despite the revolutionary nature of what is probably the most extraordinary super sports

car of our times, it is still assembled by hand. Every KTM X-BOW is built with the greatest of care and specific expertise, in compliance with the strictest quality criteria. The whole factory is of course certified according to ISO standards. Furthermore, each operation is recorded and logged electronically – even the torque values of every single tightened bolt are automatically archived. So it's not surprising that the vehicles, which have been sold all around the world, continue to impress the exclusive circle of KTM X-BOW owners with lasting effect. ➤

GT

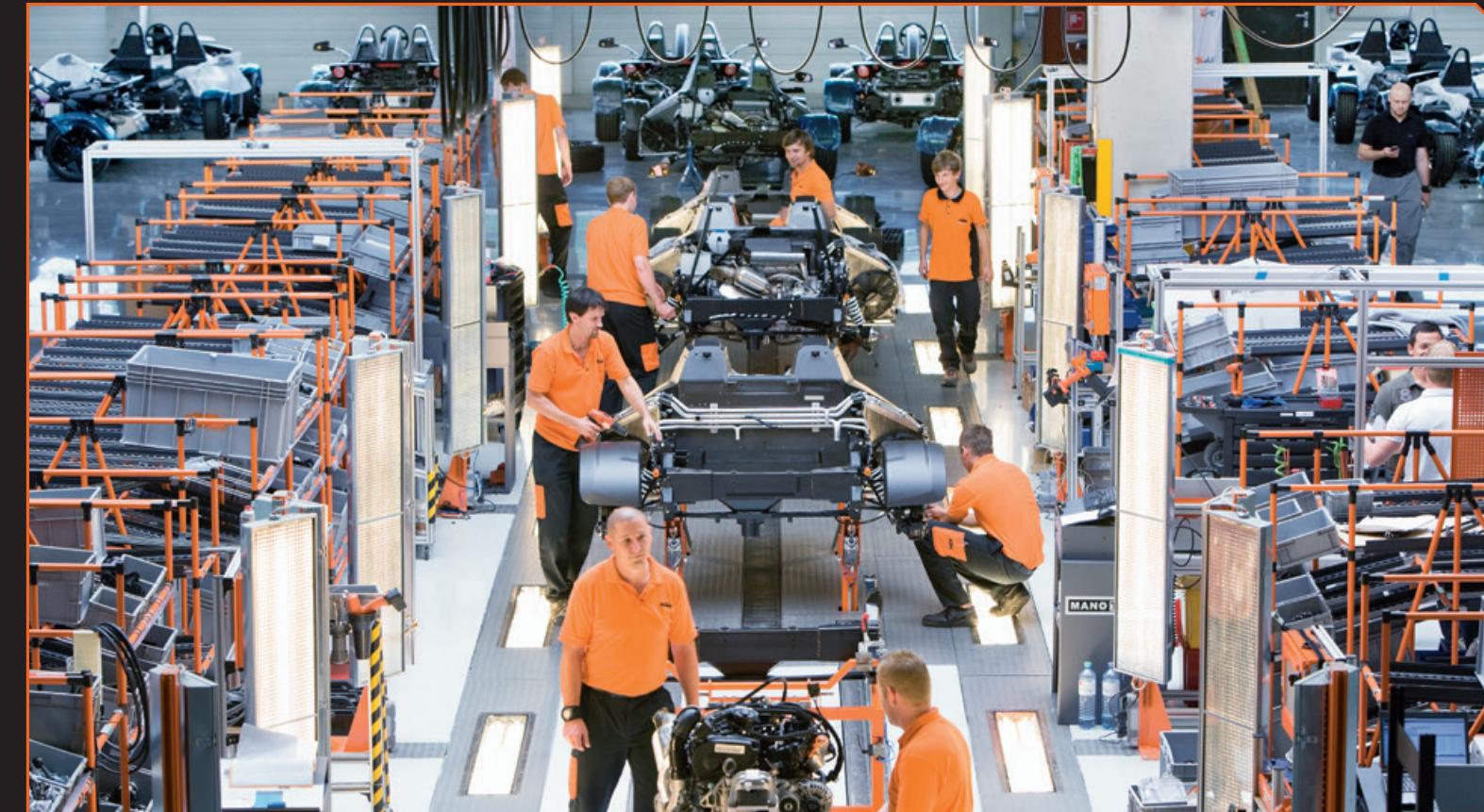
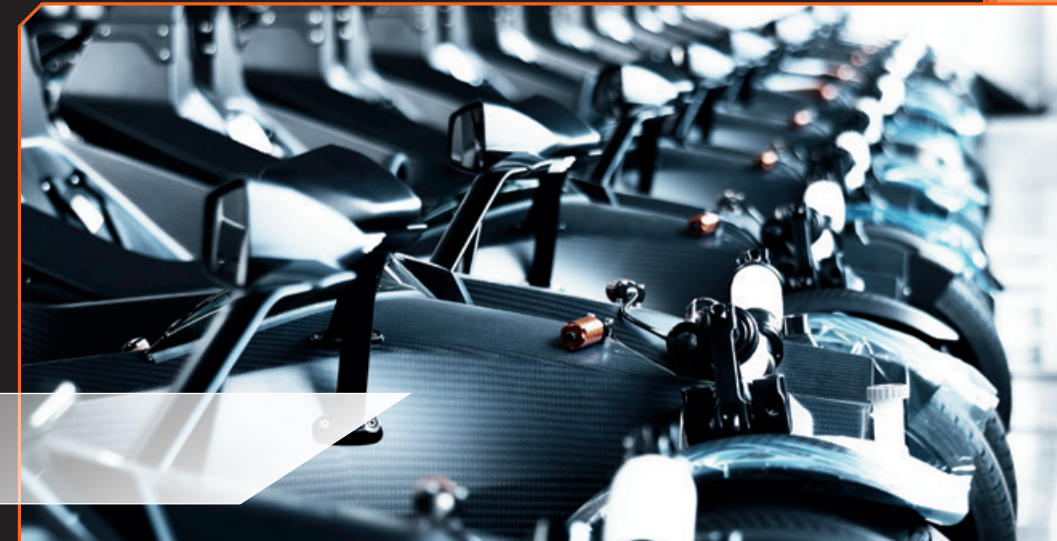

HANDMADE PERFECTION / PRODUCTION

X-BOW GT

X-BOW GT

EQUIPMENT AND DESIGN

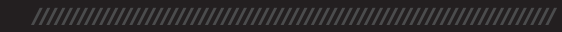

CUSTOMIZED EQUIPMENT AND DESIGN

With the KTM X-BOW, you don't buy just a car. You get the most extraordinary super sports car of today, a handmade piece of exclusivity. Naturally, KTM is keen to fulfill (nearly) every wish of its customers: Outstanding paint jobs, individual sticker design, optical and technical

tuning to the highest level, driver training with an personal instructor, pick-up directly in our manufactory including a factory tour and much more. Just ask! 



X-BOW GT

////// EQUIPMENT AND DESIGN



FINANCE – NOW. FAST. DRIVE.

A unique driving experience demands a unique means of financing. Thanks to personalised quotes and simple handling, you can get your hands on your KTM X-BOW GT quickly and reliably with KTM Finance and experience the meaning of “super sports car” for yourself, completely afresh.

No matter what requests you may have – all financial products are tailored individually to your needs. Simply ask our KTM X-BOW Team or find out more beforehand at www.ktm.com.



FINANCING
X-BOW GT

WEBSITE AND TEAM – CONTACT KTM!

Have we aroused your interest? Talk to us. Not only do we look forward to hearing your requests, desires and wishes, but also your criticism. You can contact KTM Sportcar GmbH directly – or talk to one of our

numerous importers and service partners. You'll also find further information on our website. 

CONTACT

Michael Wölfing
Head of Sales
michael.woelfling@ktm.com

Martin Gspurning
Sales
martin.gspurning@ktm.com

Hannes Huber
Sales
hannes.huber@ktm.com

Manfred Wolf
Marketing & PR
manfred.wolf@ktm.com

Birgit Kampl
X-BOW Rookies Challenge & Events
birgit.kampl@ktm.com



www.ktm.com/xbow

FIND ALL IMPORTERS AND SERVICE PARTNERS: WWW.KTM.COM/XBOW



VEHICLE DIMENSIONS

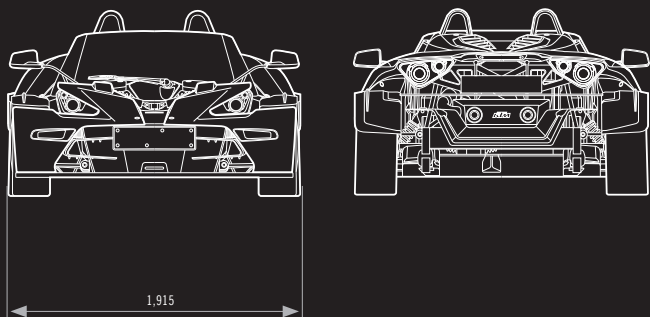
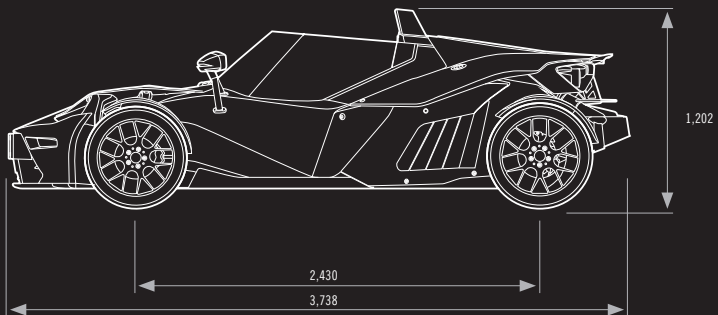

TECHNICAL DATA

ENGINE

| | |
|---------------------------|--|
| Type | In-line 4-cylinder gas engine with direct injection, exhaust turbocharging with charge-air cooling |
| Displacement | 1,984 cc |
| Performance | 220 kW (300 hp) @ 6,400 rpm |
| Max. torque | 420 Nm @ 3,200 rpm |
| Valves | 16, DOHC |
| Fuel consumption | 8.3 l/100 km |
| CO ₂ -emission | 189 g/km |

CHASSIS

| | |
|-----------------------------|--|
| Length x Width x Height | 3,738 x 1,915 x 1,202 mm |
| Wheelbase | 2,430 mm |
| Turning radius | 10.8 m |
| Wheeltrack front/rear | 1,667 / 1,628 mm |
| Power train | Rear wheel drive with mechanical limited-slip differential |
| Transmission | 6-speed gearbox, manual |
| Brake system | Sport braking system with Brembo calipers and internally ventilated brake discs 305 mm/262 mm (front/rear) |
| Tyres front/rear | 205/40 ZR17 / 255/35 ZR18 |
| Height of center of gravity | 390 mm |
| Fuel tank capacity | 40 liters |
| Weight excl. fuel | 847 kg |

MISCELLANEOUS

| | |
|---|----------------------|
| Max. speed | 231 km/h |
| Acceleration 0 – 100 km/h | 4.1 s |
| Deceleration 100 – 0 km/h | 32.9 m |
| Aerodynamic downforce 100 km/h | 25 kg |
| Aerodynamic downforce 200 km/h | 100 kg |
| Lateral acceleration | > 1.5 g (road tires) |
| Static weight distribution (front/rear) | 38:62 |

TECHNICAL DATA

GRAN TURISMO

READY TO RACE
» www.ktm.com

www.ktm.com/xbow

www.kissta.com

Photos: H. Mittelbauer, R. Scheil, J. Kennesenko, Philipp Platzer, Michaelin, Croce & Wir, KTM



Contact

KTM Sportcar GmbH
Stallhofnerstrasse 3
5230 Mattighofen

Are you looking for your own driving experience with the KTM X-BOW?
All the national contact data for KTM and KTM partners can be found
on the KTM X-BOW website:
www.ktm.com/xbow

© KTM Sportcar GmbH, 5230 Mattighofen, Austria
www.ktm.com

The driving scenes shown in this folder were shot on closed roads and performed by professional drivers. We expressly warn against any attempt to imitate these manoeuvres. The warnings and hazard notices in the owner's manuals must be observed without fail when purchasing this vehicle. All technical data represent non-binding information, believed to be correct at the time of printing. This information is subject to change without notice. Some illustrations feature optional equipment and motorsports components that are not homologated for road use.

Version May 2017



KTM_POWERPARTS **KTM_POWERWEAR**

